

Guidance on configuring volumetric targets for AUT using CIVA

Ed Ginzel¹

¹ University of Waterloo, Waterloo, Ontario, Canada

e-mail: eginzel@mri.on.ca

Dave Stewart²

²Simply AUT, Edmonton, Alberta, Canada

e-mail: david.stewart@simplyaut.ca

2023.12.07

Abstract

The main standards relating to AUT (Automated Ultrasonic Testing) using zonal discrimination have long had requirements to incorporate separate channels dedicated to detecting volumetric flaws. However, none of the standards specify how the beams are to be configured. The instructions are quite generic indicating that the channels are to ensure the complete volumetric examination of the weld through-thickness. Scattering flat bottom hole targets in a calibration block such that they evenly distribute in the volume is not a guarantee that the target placement provides the required complete volume coverage. This paper illustrates how the Coverage component of the CIVA AUT module helps to identify the best placement of volumetric targets in an AUT Zonal Discrimination procedure and prevents target redundancy.

Keywords: CIVA, phased-array, ultrasonic, volumetric, Zonal Discrimination Method

1. Introduction

AUT has become the term associated with the ultrasonic technique called Zonal Discrimination Method (ZDM) popularised for construction of pipeline girth welds since the 1980s. In its early days, a lot of effort was put into trying to make the ultrasonic results mimic radiographic results with respect to rejection. This was an unfortunate and impossible expectation that was a consequence of the long history of radiography in pipeline construction. Engineers did not seem to be satisfied with the fact that AUT was better capable of detecting the lack of sidewall fusion, that was the most prevalent and serious flaw associated with the automatic welding process. The fact that radiography was detecting and rejecting welds based on pores was considered a limitation of AUT...this despite the fact that their fracture mechanics had already concluded that porosity was not generally a serious factor in fitness for service considerations. Studies by Malik & Graville and others [1,2,3] indicate that for up to about 5%-7% porosity in welds, the transverse-tensile strength of welded joints, with reinforcement removed, is not affected by porosity. Suggestion that projected area on a radiography was not an indication of consequence to structural integrity was also documented by Boulton [4] at the Welding Institute in Abington, UK. He noted that *“Porosity is an innocuous defect from the point of view of fatigue and will only have a significant effect if present in very large amounts. However, there is a danger that porosity in such high levels could mask the presence of other, more harmful, defects; for this reason, it was decided to limit porosity to lower levels to make inspection possible.”* I.e., the rationale for such low levels of projected area on radiographs was only because the porosity might mask the presence of the more serious planar flaws.



In the early 1990s, the concept of “quantifying” porosity, by AUT, to an equivalent “projected area” was dropped by TransCanada Pipelines soon after it was tried [5]. Attempts to quantify porosity using the AUT data proved as ineffective and as subjective as the original radiography.

In the latter 1990’s a more general treatment was used. If an operator considered a weld to have clustered porosity, they were instructed to assess it, as if it was a planar flaw (e.g., non-fusion) and use the same allowed length criteria for evaluation. This meant that a subjective assessment was made (i.e., the porosity indication was considered severe enough to evaluate) and then it was treated as if it was non-fusion.

ASTM E1961 [6] makes a general statement about the incorporation of volumetric channels stating that the “system shall provide an adequate number of examination channels to ensure the complete volumetric examination of the weld through thickness in one circumferential scan”.

DNVGL-ST-F101 [7] is less specific and merely indicates that the calibration block is to contain 1.5mm diameter flat bottom holes (FBHs) as the reference targets for volumetric channels.

Both the ASTM and DNVGL standards require that added gain be used after setting the reference gain from the 1.5mm FBHs. DNVGL requires a minimum of 8dB be added for scanning. ASTM recommends 8 to 14dB be added, but added gain should not be so great as to cause interfering electrical or geometric noise that could be misinterpreted.

Since no specific guidance is found in the standards for volumetric target placement, this paper makes suggestions that may aid in technique development.

2. Weld and Target Configuration

In the earliest applications of ZDM, the welding process used was Gas Metal Arc welding (GMAW) using automatic welding machines. This welding process allowed for the use of narrow-gap weld profiles generally considered to be J-bevel or modified J-bevel.

Figure 1 illustrates the common narrow gap weld bevels used by GMAW.

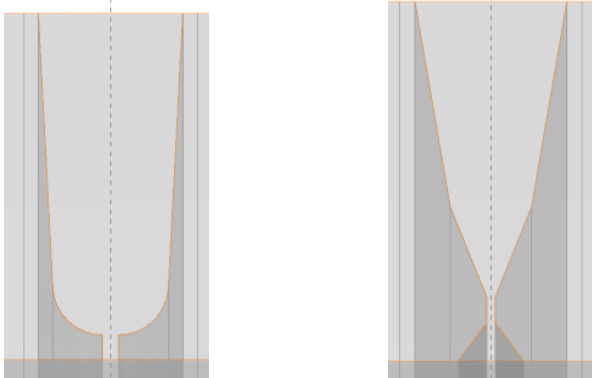

Figure 1 Narrow gap weld profiles; J-bevel (left) Modified J-bevel (right)

For these weld profiles, the placement of volumetric targets is easily accomplished by positioning the FBHs on the centreline. With the gap being relatively small, the beam from an unfocused aperture can be configured to cross the weld and cover the full weld volume when the beams are directed from both sides of the weld. Only consideration for the vertical coverage to ensure some overlap is required. This is seen in Figure 2. Even relatively thick sections can be addressed with the targets on the centreline spaced 5-7mm apart. Overtrace from adjacent volumetric targets assures high sensitivity as seen in Figure 3. It should then be kept in mind that 8dB to 14dB extra gain is added to this reference level for scanning so even the off-axis sensitivity would be brought to the reference level or more.

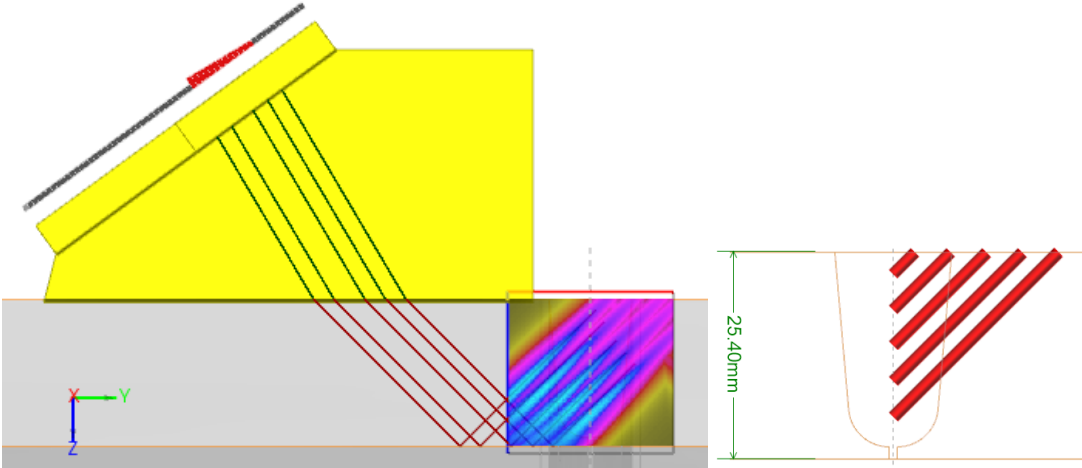

Figure 2 Beam coverage in narrow gap welds using aligned FBH targets

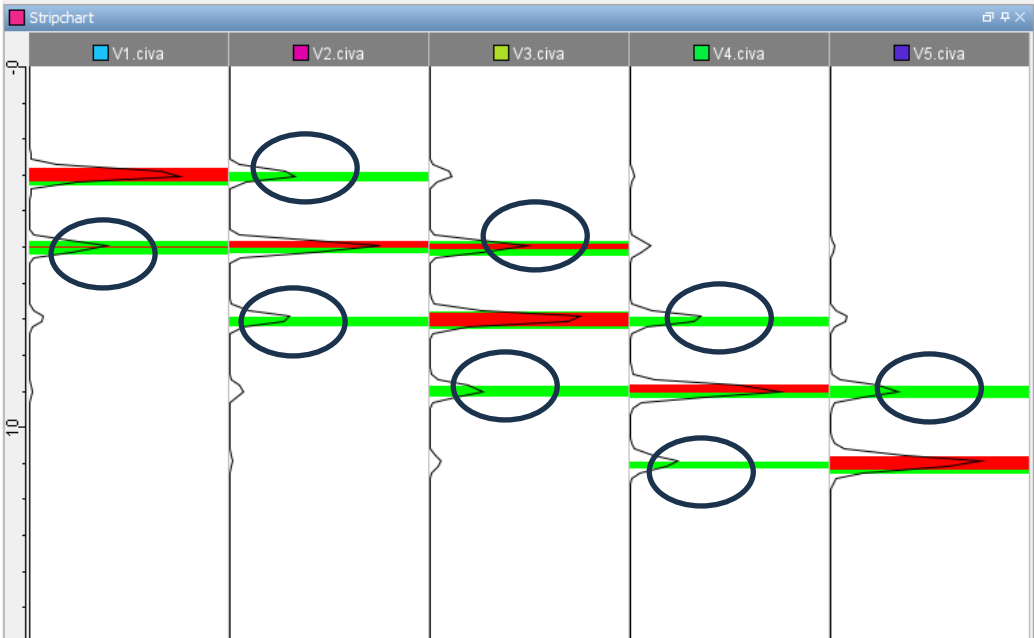

Figure 3 Volumetric channel overtrace (circled) assures off-axis coverage

As AUT using ZDM became more wide spread, confidence was sufficient in the method that it was considered suitable as a technique for manual SMAW (shielded metal arc welding) and SAW (submerged arc welding). However, these welding methods do not use a narrow gap weld bevel profile. Instead, V-bevels or compound V-bevels are used. These profiles have wider openings and use more weld metal. The volume coverage is therefore not as simple as the narrow gap weld profiles and extra channels are required off-set from the centreline.

Figure 4 illustrates how some targets might be positioned in an attempt to obtain “full volume coverage”. The end-points of 1.5mm diameter flat bottom holes are indicated on a 6x6mm grid pattern covering the weld volume. Targets on the centreline would be made for both upstream and downstream facing beams, whilst targets offset from the centreline would be made facing the beams on the side they are offset.

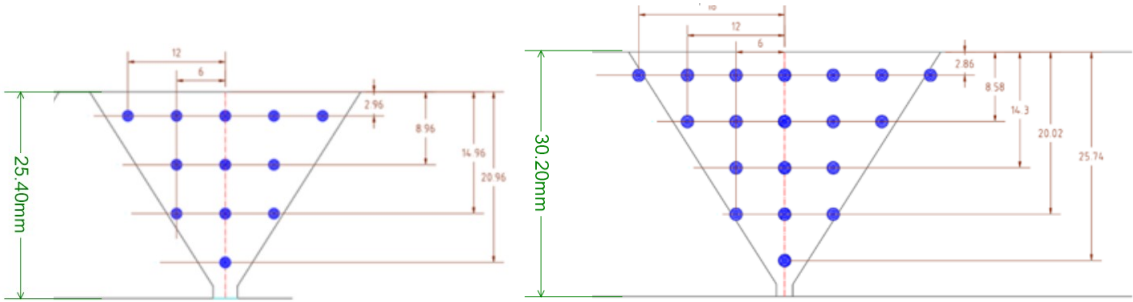

Figure 4 Wide gap weld profiles with offset targets

However, when such high-density targets are used to position the beams, the coverage verification may not be as effective as initially thought. The CIVA AUT coverage module can be used to illustrate how portions of the volume are not as well covered as others and how some channels are redundant.

3. Redundant Volumetric Targets

In order to explain how high-density volumetric targets become redundant, it must be understood that when configuring a ZDM technique, a separate beam is used on each target. The beam is then positioned to obtain a maximum amplitude response from that target. Using the two examples in Figure 4, we can see that there would be 8 targets on each side of the weld profile for the 25.4mm thickness and 12 targets on each side of the weld profile for the 30.2mm thickness. That would be 16 volumetric channels for the 25.4mm thickness and 24 volumetric channels for the 30.2mm thickness.

Redundancy of targets is best illustrated when the rays are drawn that would be required to impinge on each target. In the 30.2mm thickness, there are 12 targets used to “fill the volume” of one side of the weld in the high-density target option. Yet when we draw a ray to represent each beam, we can see that 4 of the 12 targets are using duplicate beams. This is illustrated with Beamtool ray tracing in Figures 5 and 6.

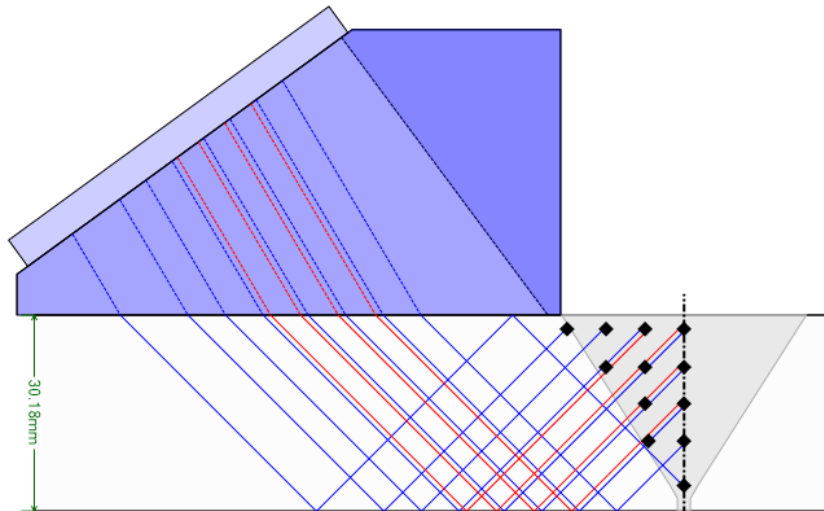

Figure 5 Redundancy of beams when all targets are used for the 30.18mm wall (red lines duplicate)

In the 25.4mm wall bevel, there are 8 targets used to “fill the volume” of one side of the weld in the high-density target option. Yet when we draw a ray to represent each beam, we can see that 2 of the 8 targets are using duplicate beams.

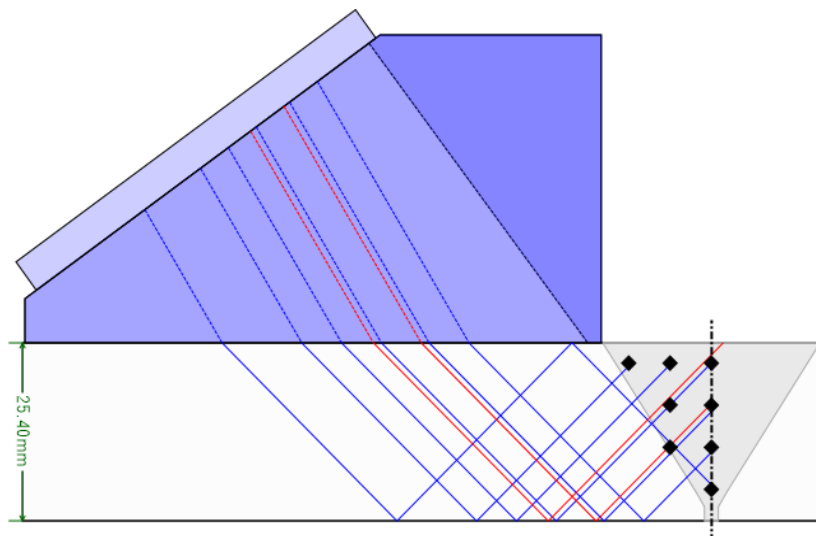

Figure 6 Redundancy of beams when all targets are used for the 25.4mm wall (red lines duplicate)

Note; the lowest volumetric target in these examples use a 1.5mm diameter FBH drilled from the inside surface of the pipe so a 1.5 skip path is required. This is because the start element of the active aperture could not be made far enough along the linear array to allow the target to be hit with a 45° beam in the second half-skip like upper targets.

When the beam coverage plots from CIVA AUT module are overlaid on the Beamtool ray tracings, the equi-spacing of the beams to address the 6x6mm grid spacing of the targets illustrates good volume coverage, but 2 of 25.4mm thickness beams are identical and 4 of the beams for the 30.2mm thickness are also identical. Figure 7 provides the CIVA coverage maps overlaid on the ray tracings. Although separate delay laws were used for the offset targets, it is apparent that the grid pattern does not provide improved volume coverage. Instead, these extra targets simply incur extra cost in machining and clutter the AUT display with redundant data.

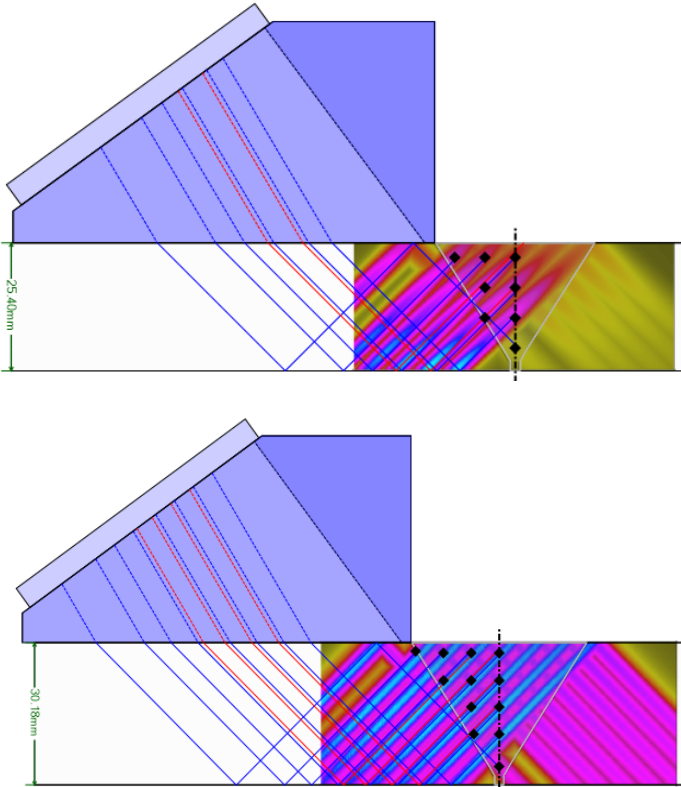

Figure 7 CIVA AUT Volume coverage overlaid on ray paths to illustrate redundancy

Because the delay laws used for volumetric coverage are not focussed, the beam intensity along the centre ray is relatively uniform over the entire sound path through the weld volume. It is also noted that although volumetric targets are positioned so the flat bottom holes for each probe are placed on the centreline and offset just on the probe side; the beam actually crosses the centreline and provides coverage of the far side of the weld. Since there is a probe on each side of the weld, the volumetric coverage is made with two beams 90° to each other.

4. Discussion

Civa AUT Coverage modelling of the multiple volumetric channels shows that the volume can be adequately covered when the beam centrelines are equi-spaced. To illustrate how beam coverage can be assessed with the Civa AUT module, a simple V-bevel is modelled with a standard 3-target setup with the 1.5mm diameter FBH targets aligned on the centreline.

The weld bevel is 35° in a nominal 19mm wall thickness. A typical positioning of the volumetric targets is seen in Figure 8.

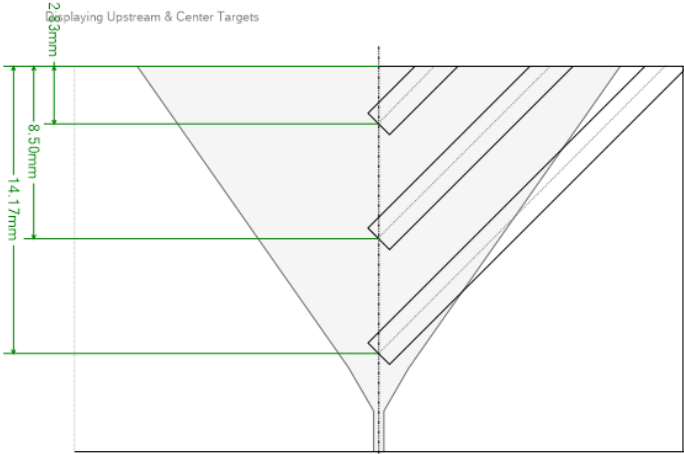

Figure 8 Volumetric target placement in 35° V-bevel in 19mm wall thickness

When the strip chart for these targets is seen, it is obvious that the response from the cap notch on the probe side is very weak. This suggests poor coverage of the volume between the weld edge and the upper centre surface.

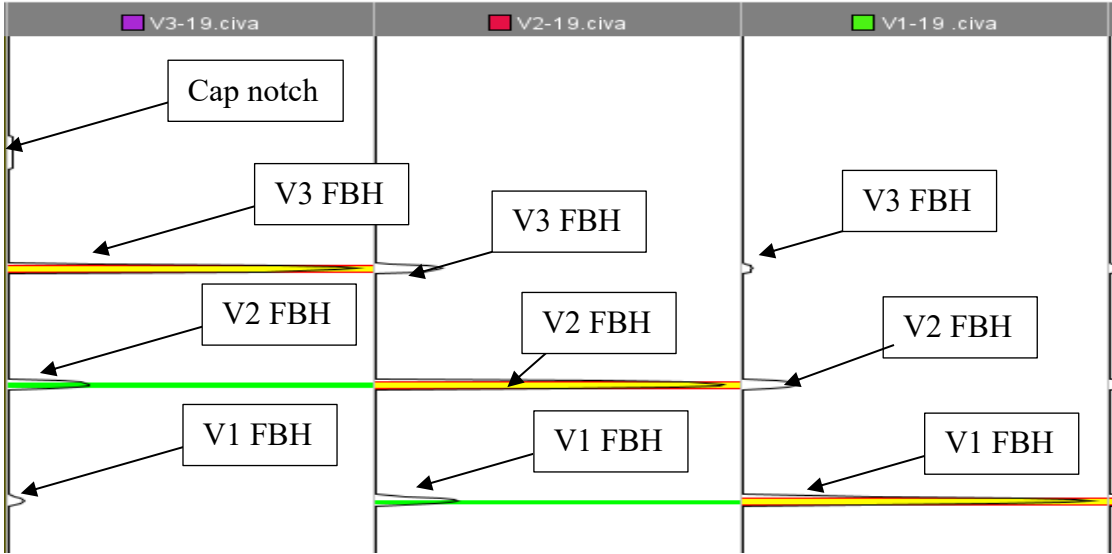

Figure 8 Strip Chart of 3 Channel volumetric for 19mm wall V-bevel

The lack of sensitivity in that area is even more noticeable when the coverage of the beams is displayed in the Coverage maps in CIVA as shown in Figure 9. CIVA measurement tools suggest another FBH target at 3mm below the surface and offset 7mm from the centreline target can provide a suitable target to position an extra beam that would afford the uniform sensitivity across the weld volume.

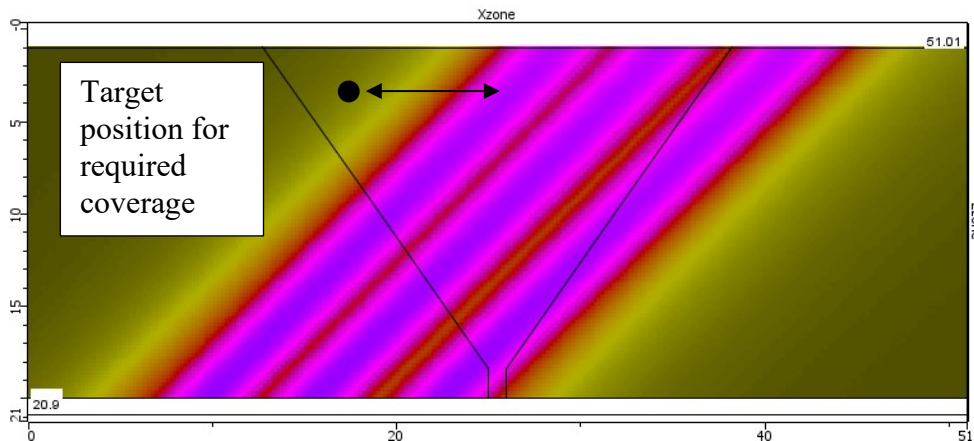

Figure 9 CIVA Coverage map of 4th half-skip used for volumetric channels in 19mm wall with V-bevel

Adding an extra volumetric target to the position indicated by the CIVA sensitivity map provides the extra coverage required to ensure a uniform sensitivity through the volume of interest. Figure 10 illustrates the required added target identified by CIVA and the associated coverage that the extra beam provides.

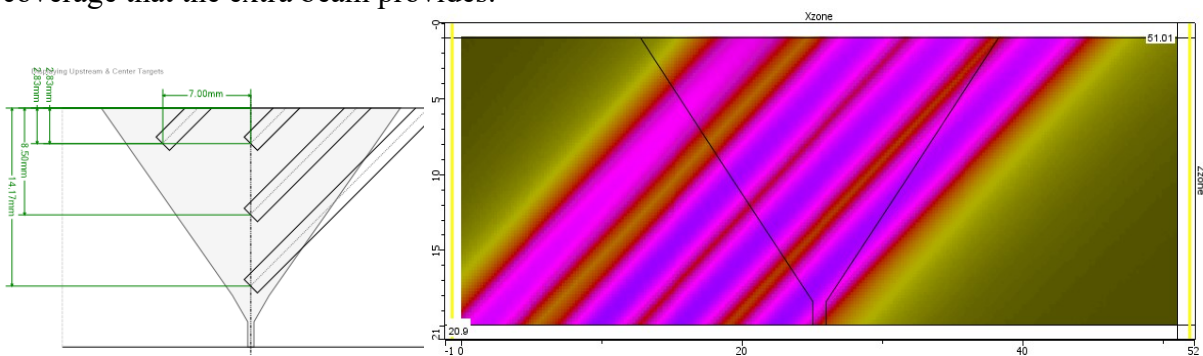

Figure 10 Extra Volumetric target required as identified by CIVA Coverage map and the resulting Coverage with the added channel

The beam intensity maps suggest that the only purpose of the volumetric targets is to set the offset of the beam and establish a single point sensitivity level. When the FBH targets are not positioned to allow equi-spacing of the paths through the weld volume, the ray paths can leave gaps in coverage.

The purpose of volumetric targets should therefore be only 2-fold;

1. To position beams
2. To set a uniform sensitivity for each volumetric channel

These requirements can be accomplished with a pattern of targets that assures equi-spacing of the beams. Extra targets in front of or behind these targets provide no benefit. Positioning of these targets should allow setups to demonstrate adequate beam spread achieved at the scanning sensitivity.

Spacing must be done with consideration of the aperture used and frequency of the probe. Beam steering without focussing is recommended in the active plane.

By simply observing the strip chart in Figure 11, with the extra Volumetric channel, it can be seen how coverage is improved. The extra volumetric channel is identified as V3A and it sees the cap notch at 10B more than the V3 channel. Setting the extra V3A target to reference sensitivity the cap notch seen on channel V3A can be detected at about 20% of reference. Adding the required 12dB gain for scanning, this would raise the off-axis response of the 1mm notch to 80% screen height.

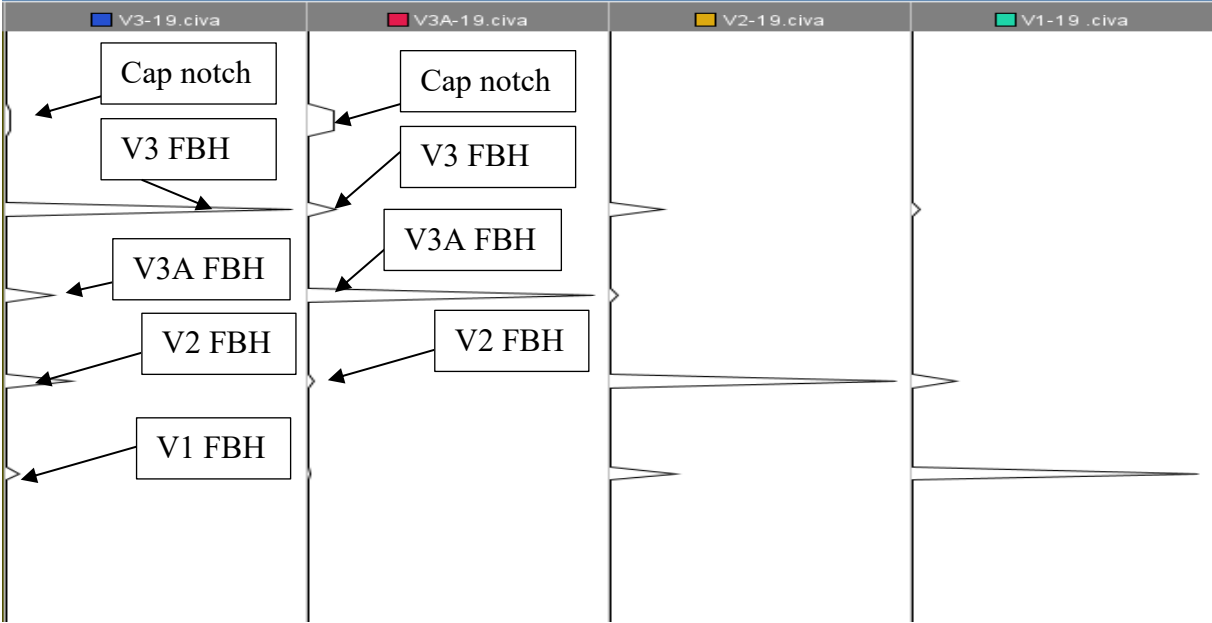

Figure 11 Volumetric channel V3A demonstrates significantly improved detection by detecting the Cap Notch 10dB more than channel V3 at reference sensitivity

The effect of adding 12dB for scanning essentially makes no part of the weld volume have sensitivity below reference value, as seen in Figure 12.

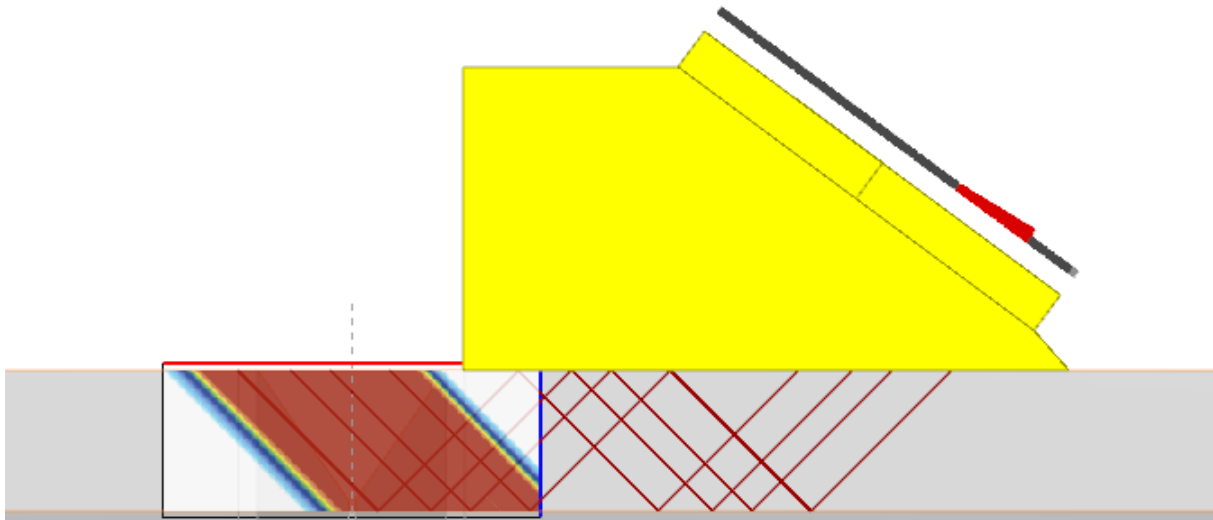

Figure 12 Volumetric sensitivity coverage with 12dB added for scanning

5. Discussion

High density targets for volumetric channels in AUT setups tend to produce redundant and ineffective coverage. Far better is a technique that assures equi-spacing of beams in the weld volume and provides evidence that overtrace exists between the volumetric beams. For narrow gap welds, this can usually be accomplished with flat-bottom holes at 45° aligned along the weld centreline. For V-bevel welds, beam spread may not be adequate to assure coverage so offset targets are required. Offset targets could be in addition to the centreline targets, or could be arranged to demonstrate that the beams are positioned with equi-spacing in the weld volume from each direction (upstream and downstream). Typically, spacing of 6mm to 7mm vertically and laterally (when offset targets are required) is adequate. Focussing should not be applied to delay laws used for volumetric channels. Aperture size and nominal frequency of the probe used will determine the off-axis coverage that can be achieved. Adequate spacing of targets should be confirmed by assessing the strip-chart display to ensure that adjacent volumetric target responses are seen with adequate overtrace. Since most standards require an additional gain of 8 to 12dB be added to the volumetric channels when scanning a weld, this assures that even off-axis responses will be detected at a relatively high amplitude.

CIVA AUT module provides useful tools to identify the sensitivity coverage that can be achieved with the delay laws selected. As well, it offers opportunity to identify the locations where offset targets should be positioned to confirm full volumetric coverage and the strip chart displays provide an indication of the overlap between volumetric channels. With these tools, optimal calibration blocks and delay laws can be configured for each project.

References

1. Malik, L. & Graville, B., Structural Integrity of Mechanized Gas Metal Arc Welds Containing Root Porosity, Structural Integrity Group, Final Report, Canmet Project 9252/01, 1993
2. Harrison, J.D., The Basis for a Proposed Acceptance Standard for Weld Defects: Part I, Porosity, IIW Doc. XIII-817-77
3. Green, W.L., The Effects of Porosity on Mild Steel Welds, Welding Journal Supp., Vol 23, No. 5 May 1958
4. Boulton, C.F., Acceptance Levels of Weld Defects for Fatigue Service, Welding Research Supplement, January 1977
5. Ginzel E., Ginzel, R., Gross, B., Hoff, M., Manuel, P., Developments in Ultrasonic Inspection for Total Inspection of Pipeline Girth Welds, 8th Symposium on Pipeline Research, Houston, Texas, 1993
6. ASTM 'Standard Practice for Mechanised Ultrasonic Examination of Girth welds Using Zonal Discrimination with Focused search Units', E1961-21
7. DNVGL ST-F101, "Submarine Pipeline Systems, Appendix E, Automated Ultrasonic Girth weld testing, 2017